

**Vibrabsorber**

TYPE	A	H	B	C	E	M	CODE
VT 25	75	120	30	12	50	M-8	20201
VT 50	75	120	30	12	50	M-8	20202
VT 75	75	120	30	12	50	M-8	20203
VT 100	75	120	30	12	50	M-8	20204
VT 125	75	120	30	12	50	M-8	20211
VT 150	120	160	30	16	80	M-12	20205
VT 200	120	160	30	16	80	M-12	20210
VT 250	120	160	30	16	80	M-12	20206
VT 350	120	160	30	16	80	M-12	20207
VT 500	140	180	30	16	100	M-14	20208
VT 750	140	180	30	16	100	M-14	20209

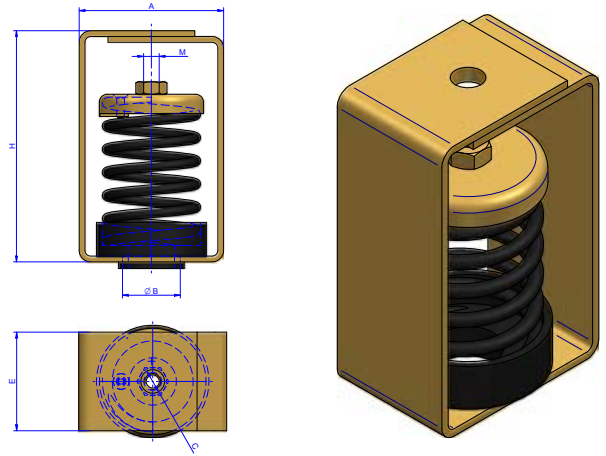

AMC Dynamic Natural Frequency range  
MECANOCAUCHO Type VT

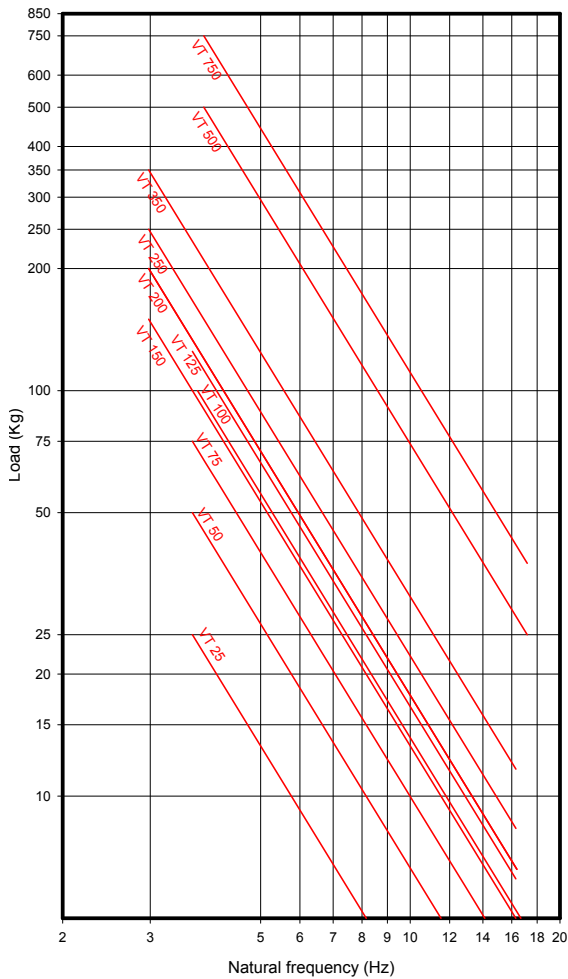

AMC LOAD DEFORMATION  
MECANOCAUCHO Type VT

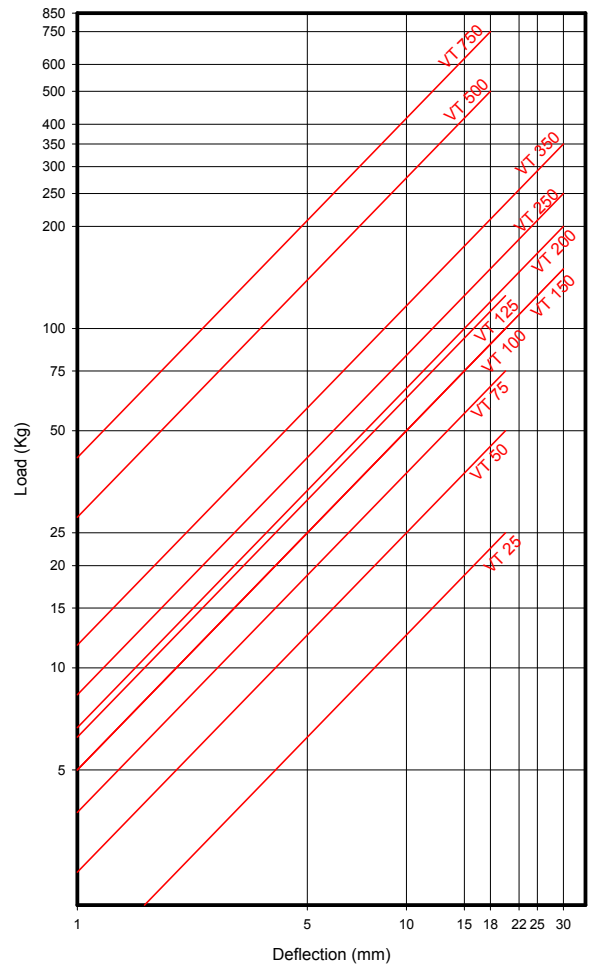

To find out about the advantages of Sylomer in the vibrabsorber® system, go to pages 14,15,16