

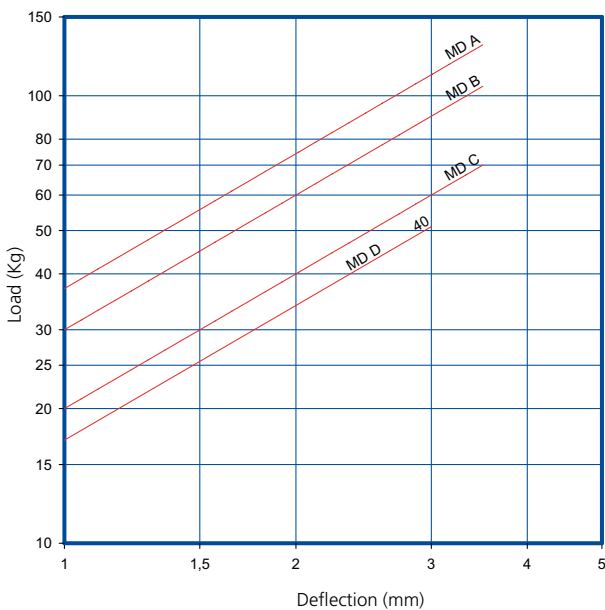

MD DEFLECTION

LOAD DEFLECTION GRAPHS
TYPE MD AMC-MECANOCAUCHO®



TYPE	CODE	WEIGHT
	Load kg	(g)
A	135210	238
	130	
B	135212	238
	105	
C	135213	238
	70	
D	135219	238
	50	

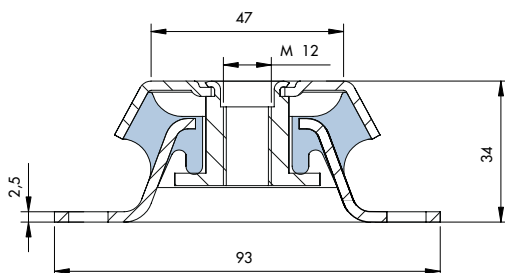

MD

DESCRIPTION

The AMC-Mecanocaucho MD-type mounts have similar architecture to the BSB and BRB. The advantage of this mount is that it is a high-damping elastic compound.

Its special mix affords it a high degree of antivibration isolation and offers great stability to suspended equipment.

TECHNICAL CHARACTERISTICS

- Metal hood that protects the part from possible oil splashes.
- It has an electrolytic coating that protects the part from corrosion.
- They have an interlocking metal component that provides a fail-safe protection for mobile applications. This device limits the ascending vertical movement when the mounting is submitted to shocks at traction.

APPLICATIONS

This mount has been specially designed to insulate engines that produce high-amplitude vibrations.

Engines from 1 to 3 cylinders, Motor Pumps, Gen Sets, Compressors, Ventilators...

WHEN IS IT USED?

The MD-type AMC-Mecanocaucho® works as an antivibration mount but also as an engine stabiliser. This mount is used when conventional rubber metal mounts do not offer sufficient stability to the suspended equipment.

The MD is installed in small engines of 1, 2 and 3 cylinders which are particularly unstable.

These mounts are suitable for the suspension of machines which are started and stopped a lot and where the passage of resonance needs a high degree of damping or work in conditions which are close to the frequency of resonance of the system.

Diesel engines require MD mounts, particularly when they have few large-diameter cylinders, which makes the engine create high-amplitude vibrations, therefore requiring extra damping to correct these high amplitudes.

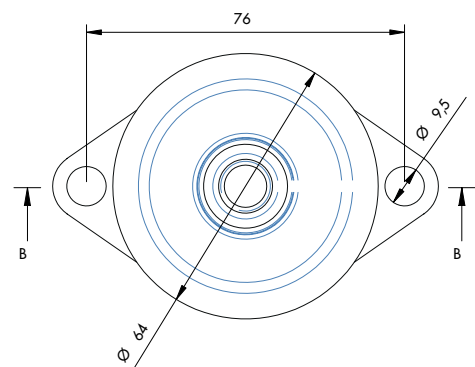

Vibration level measured in the engine

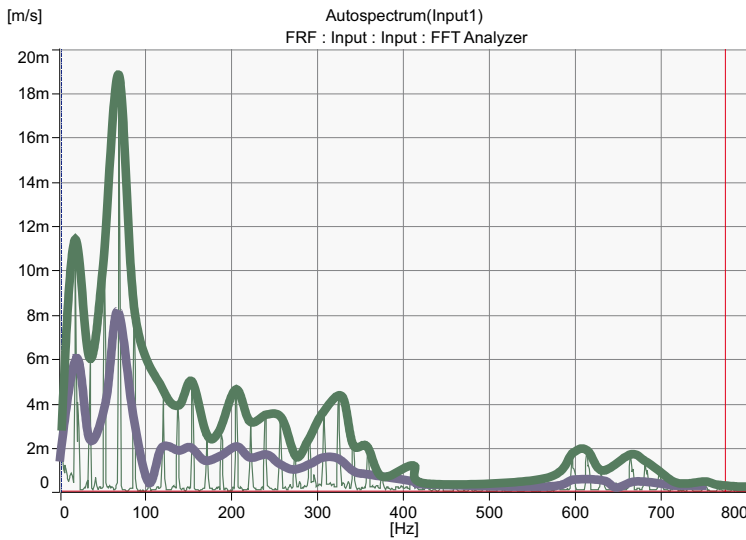

— Natural rubber mount
— MD mount

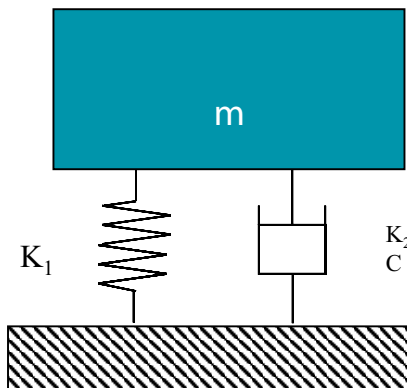

K_1 = Main stiffness - K_2 = Secondary stiffness
 C = Damping coefficient - m = Mass



It is a very suitable mount for engines where it is not physically possible to install the antivibration mounts at the same height as the crankshaft.