



BRB

DESCRIPTION

The BRB type AMC Mecanocaucho® mounts are antivibration elements which work the rubber in shear and compression. Their tall height section produce large deflections, low natural frequencies, and excellent vibration isolation results. This range of mounts is suitable for applications where high vibration isolation in the 85-95% range is a priority.

TECHNICAL CHARACTERISTICS

- The top metal hood protects the rubber from the Ozone, UV rays, diesel or oils which damage the rubber.
- The metal parts have a suitable anticorrosive treatment for outdoor applications. RoHS compliant.

- They have an interlocking metal component that provides a fail-safe protection for mobile applications. This device limits the ascending vertical movement when the mounting is submitted to shocks at traction.
- The mounts are clearly identified, as the baseplates are engraved with the type and hardness, which makes it possible to easily recognise the part even after several years of use.
- The hood has a cross stamped on the top, which enhances its rigidity on mobile applications and also improves the evacuation of oils or liquids that precipitate onto it.

APPLICATIONS

This mount is suitable for the isolation of mobile rotating machines which are exposed to axial and radial shocks, dripping oil, diesel or exposure to the weather. It is particularly interesting for applications where a high level of vibration isolation is required.

TYPE	AMC	CODE	CODE	CODE	CODE
		40 Sh	50 Sh	60 Sh	70 Sh
BRB 50	Load (kg)	20	40	60	80
BRB 60	Load (kg)	30	45	65	75
BRB 65	Load (kg)	50	75	120	140
BRB 70	Load (kg)	50	75	120	140
BRB 80 M10	Load (kg)	80	130	175	235
BRB 80 M12	Load (kg)	80	130	175	235
BRB 110 M12	Load (kg)	200	305	420	450
BRB 110 M16	Load (kg)	200	305	420	450
BRB 125	Load (kg)	310	450	700	900
BRB 150	Load (kg)	450	570	800	1000
BRB 180	Load (kg)	875	1110	1700	2630
BRB 220	Load (kg)	1600	2400	3400	4200

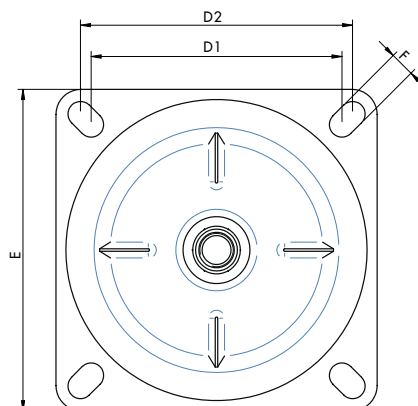
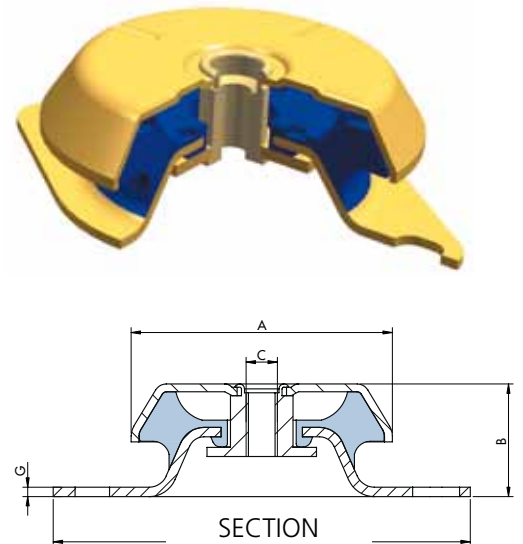

BRB 150 S. B.
BRB 180
BRB 220

BRB 50
BRB 60
BRB 65
BRB 70
BRB 80
BRB 95
BRB 110
BRB 125
BRB 150

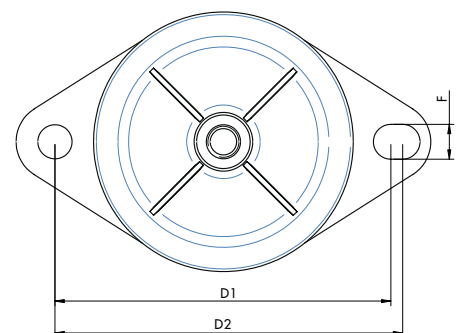

TYPE	A	B	C	D1 (Min)	D2 (Max)	E	G	F	AMC	CODE 40 Sh	CODE 50 Sh	CODE 60 Sh	CODE 70 Sh	WEIGHT (g)
BRB 50	50	25	M-8	63	70	85	2	6,5	Ref	135451	135453	135455	135457	100
BRB 60	64	35	M-10	76	91	110	2,5	9	Ref	135101	135405	135103	135104	225
BRB 65 M10	65	35	M-10	76	91	110	2,5	9	Ref	135421	135422	135423	135424	243
BRB 65 M12	65	35	M-12	76	91	110	2,5	9	Ref	135431	135432	135433	135434	243
BRB 70	65	35	M-12	100	100	120	3	11	Ref	135251	135252	135253	135254	253
BRB 80 M10	83	35	M-10	108	110	130	3	11	Ref	135231	135232	135233	135234	398
BRB 80 M12	83	35	M-12	108	110	130	3	11	Ref	135275	135276	135277	135278	398
BRB 110 M12	106	41	M-12	136	150	170	3,5	12,5	Ref	135241	135242	135243	135244	857
BRB 110 M16	106	41	M-16	136	150	170	3,5	12,5	Ref	135331	135332	135333	135334	857
BRB 125	123	48	M-16	155	161	190	4	14	Ref	135618	135620	135622	135624	1170
BRB 150 B.C. Square base	155	53,5	M-16	125	132	164	4	14,5	Ref	135205	135206	135207	135208	2030
BRB 150	155	53,5	M-16	176	188	218	4	14,5	Ref	135161	135162	135163	135164	1840
BRB 180	183	86	M-20	146	146	180	5	14,5	Ref	135391	135392	135393	135394	3100
BRB 220	225	105	M-24	180	180	220	6	18,5	Ref	135201	135200	135202	135203	6716

DYNAMIC BRB

NATURAL FREQUENCIES
AMC-MECANOCAUCHO® BRB TYPE

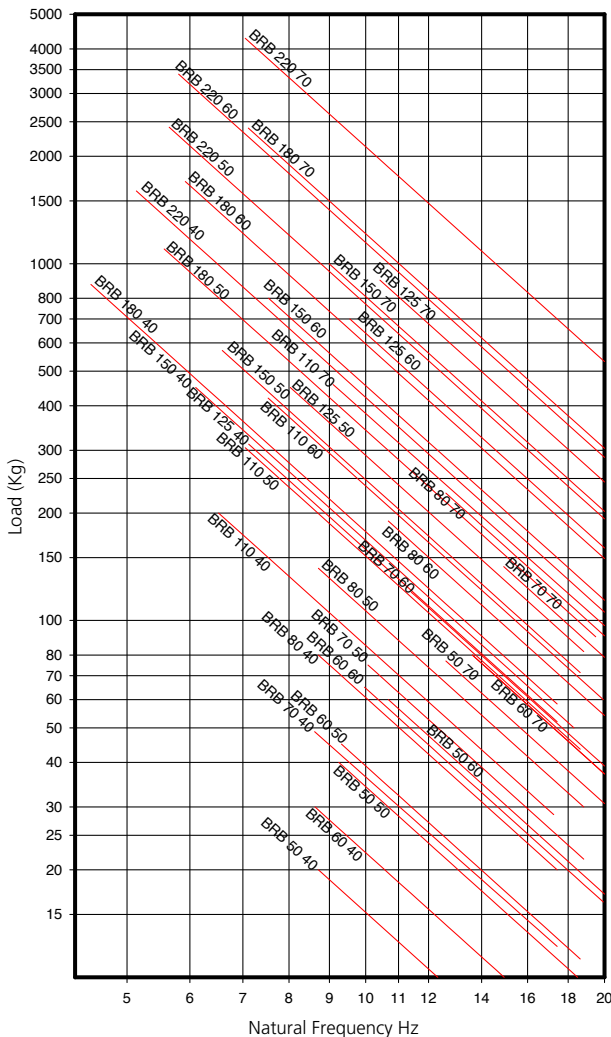

DEFLECTION BRB

LOAD DEFLECTION GRAPHS
AMC-MECANOCAUCHO® BRB TYPE

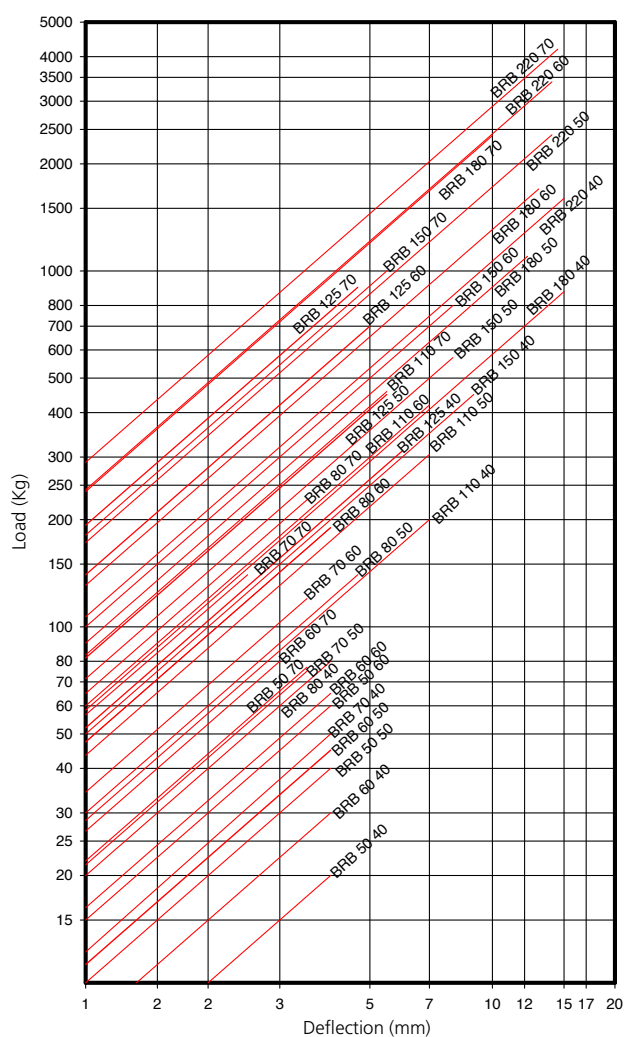

* In order to adapt its products to the state of the art, AMC .A. reserves the right to modify the conception and manufacture of the materials presented in this catalogue without prior notice