

SV

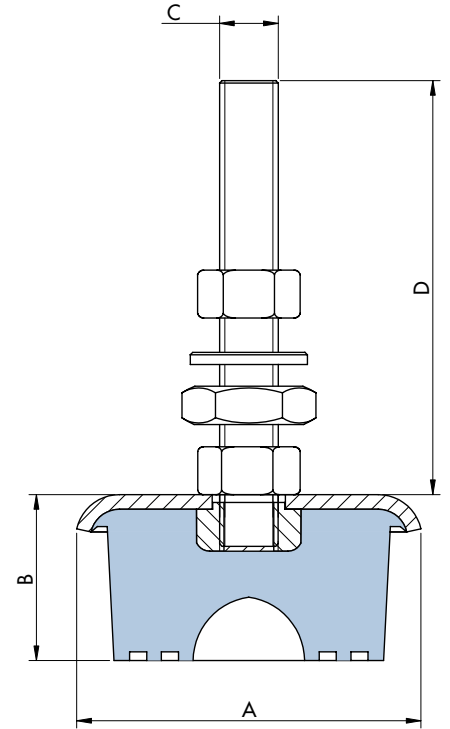

TYPE	DIMENSIONS mm.				LOAD kg.		WEIGHT (g)	CODE
	A	B	C	D	MIN	MAX		
000	40	23	M-8	48	20	80	89	143001
00	60	28	M-10	81	60	120	235	143002
0	70	32	M-12	89	90	160	350	143003
1	85	32	M-12	89	130	350	456	143004
2	100	40	M-14	109	270	600	702	143005
3	120	37	M-16	116	450	900	954	143006
4	140	55	M-16	116	700	1200	1513	143007
5	160	60	M-16	116	1100	1750	1865	143008
6	180	70	M-24	138	1500	2500	3034	143009
7	210	75	M-24	138	2100	3750	4248	143010



MECANOCAUCHO® JT TYPE

APPLICATIONS

Levelling machine mounts

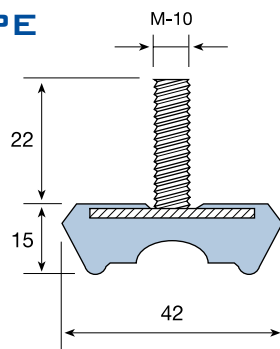

HARDNESS	LOAD Kg.	CODE	WEIGHT (g)
50	25-40	144001	53
75	75-100	144002	53



MECANOCAUCHO® SX TYPE

APPLICATIONS

Levelling machine mounts

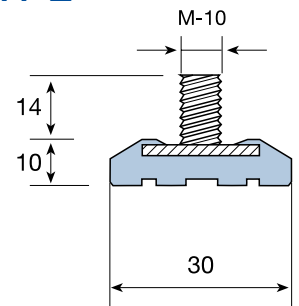

HARDNESS	LOAD Kg.	CODE	WEIGHT (g)
50	10-25	145001	25

LOW SV

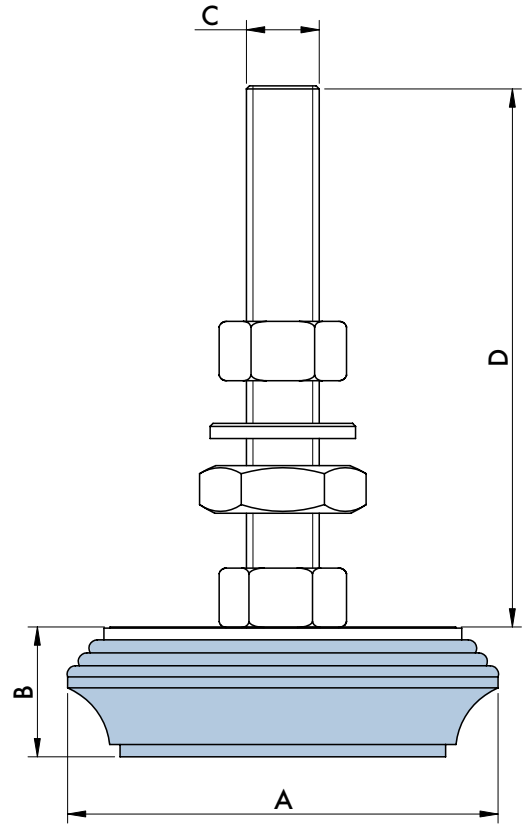

TYPE	DIMENSIONS mm.				LOAD Kg.		WEIGHT (g)	CODE
	A	B	C	D	MIN.	MAX.		
00 B	60	18	M-10	81	60	120	187	147001
0 B	70	20	M-12	89	90	160	286	147002
1 B	85	25	M-12	89	130	350	382	147003
2 B	100	20	M-14	109	270	600	574	147004
3 B	120	28	M-16	116	450	900	867	147005
4 B	140	33	M-16	116	700	1200	1300	147006
5 B	160	36	M-16	116	1100	1750	1556	147007

* Can be supplied in stainless steel

MECANOCAUCHO® SM TYPE

APPLICATIONS

Levelling machine mounts

TYPE	DIMENSIONS mm.				LOAD Kg. MAX.	CODE	WEIGHT(g)
	A	B	C	D			
S.M.-40	40	18	M-8	48	45	146001	79
S.M.-60	65	28	M-12	89	150	146002	307
S.M.-70	75	29	M-12	89	250	146003	363
S.M.-90	95	30	M-12	89	500	146004	573
S.M.-120	125	31	M-16	116	1.000	146005	904

