



SPS

DESCRIPTION

AMC-MECANOCAUCHO® SPS type mounts are comprised of two pressed metal parts. A cup shaped Top Cap and a pressed steel inverted cup shaped base, two moulded rubber sections are assembled to the metal parts and secured by means of a swaged centre insert which is threaded .

TECHNICAL CHARACTERISTICS

Due to the design SPS mounts can work with compression and tensile, loads isolating effectively by using the friction of the rubber section with the surfaces of the assembled metal parts. It is most effective in applications where high frequency vibrations are predominant.

Various rubber compounds are available for insertion, depending upon the applications to be considered, high temperatures ,oil and diesel resistance , ageing resistance against Ozone attack .

APPLICATIONS

With a captive rubber unit the SPS mounts afford total safety in Mobile applications. They are compact in design for the range of loads to be supported and can be manufactured in Stainless Steel metal parts as an option for Food Industry applications, and coupled with appropriate compounds for the environments involved.

Applications range from high speed operation equipment such as Refrigeration units, Compressors , Transformers , HVAC units on trains or Coaches .

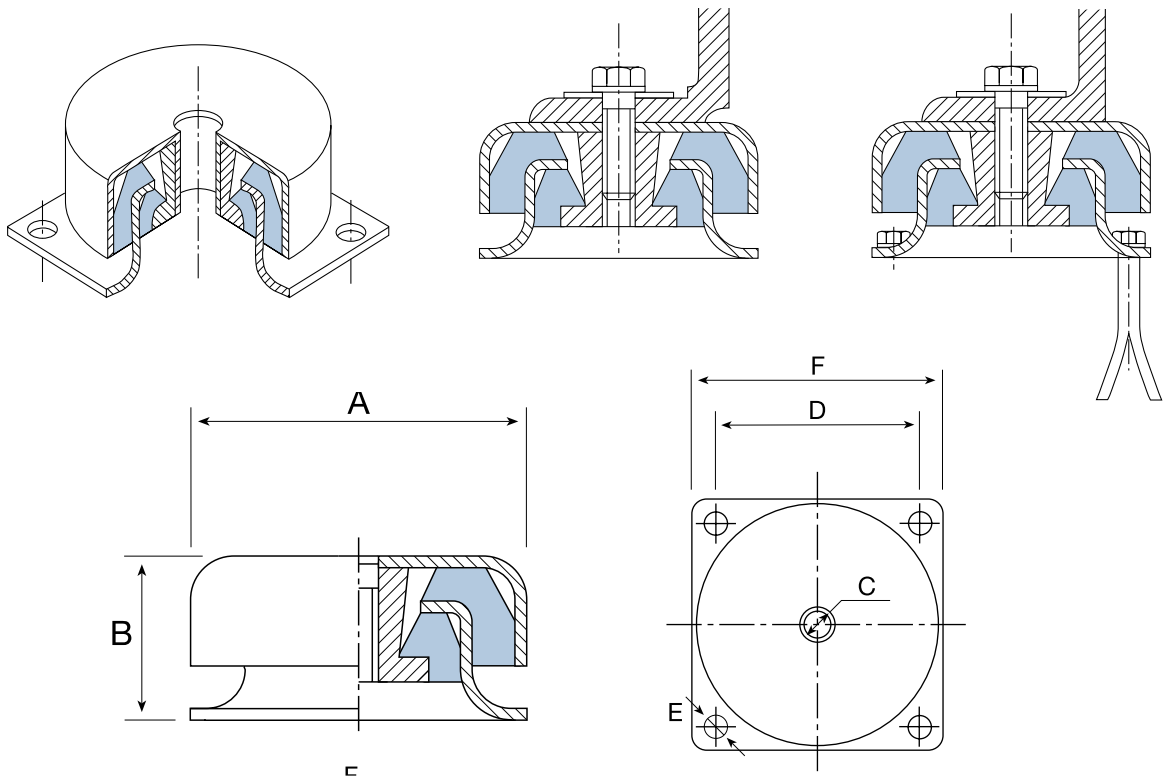

TYPE	A	B	C	D	E	F	AMC	CODE	CODE	CODE	WEIGHT (g)
								45 Sh	60 Sh	75 Sh	
SPS 020	50	28	M-8	50	6	60	Ref Load (kg)	140001	140003	140005	171
								80	100	150	
SPS 120	76	38	M-10	63,5	6,7	76	Ref Load (kg)	140002	140004	140006	524
								180	240	300	
SPS 220	90	51	M-12	90	11	114	Ref Load (kg)	140007	140008	140009	971
								170	300	450	

DYNAMIC SPS

AMC NATURAL FREQUENCIES
MECANOCAUCHO® SPS TYPE

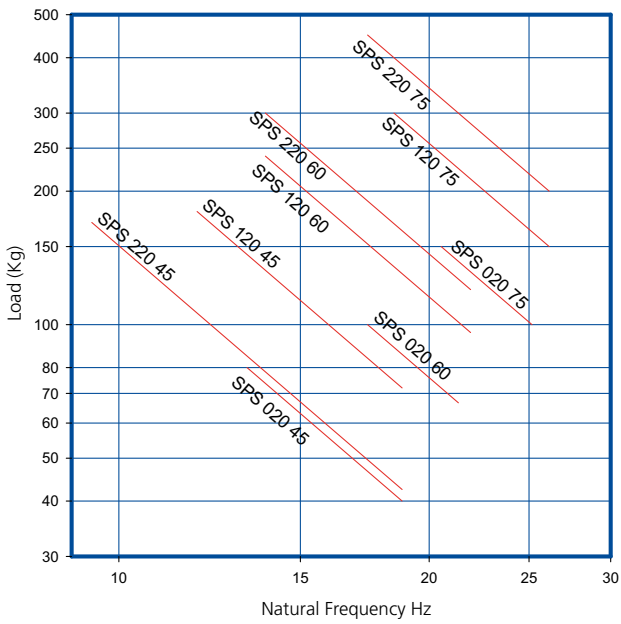

SPS DEFLECTION

AMC LOAD DEFLECTION GRAPHS
MECANOCAUCHO® SPS TYPE

