

SH



“Vee” inclined installation configuration

DESCRIPTION

Each mount consists of two heavy duty square outer plates with corner hole fixings fully bonded to circular profiled rubber layers separated by interleaf plates.

The AMC-MECANOCAUCHO® type SH mounts provide high static and shock load capacities in compression with a minimum deflection, maintaining a low shear stiffness rate.

TECHNICAL CHARACTERISTICS

The AMC-MECANOCAUCHO® type SH mounts are designed for long lasting heavy duty applications.

They can be supplied in 3 different hardness and 3 different sizes to suit applications where the compression load per mount is between 2 to 40 Tons.

APPLICATIONS:

High compression capacity, low shear stiffness and relatively low installed heights make the mounts ideal for: Vibratory rollers, Mills, Presses, Heavy machinery, Feeder screens.

Due to their high load capacity these mounts are also used as point bearings for the vibration isolation of building structures.

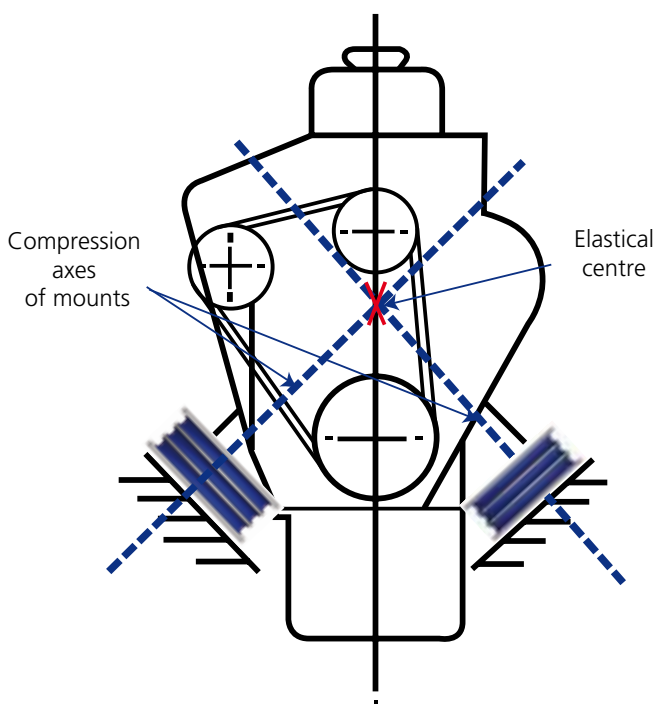

AMC-MECANOCAUCHO® technical department can calculate a precise angle configuration in order to achieve an optimum compromise between isolation and stability of the suspended equipment

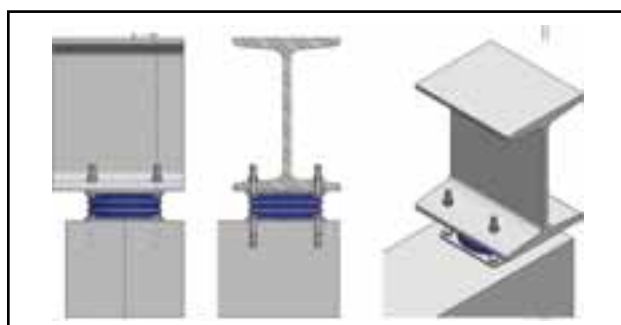

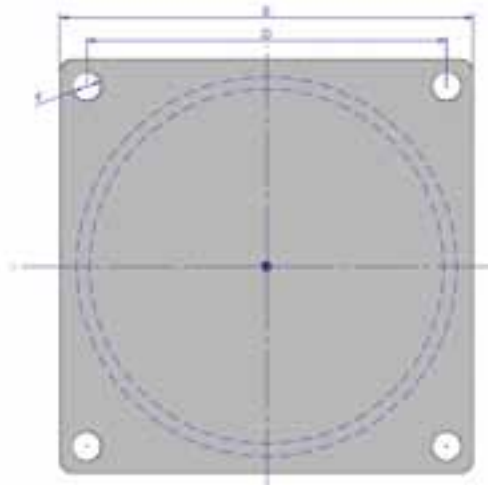
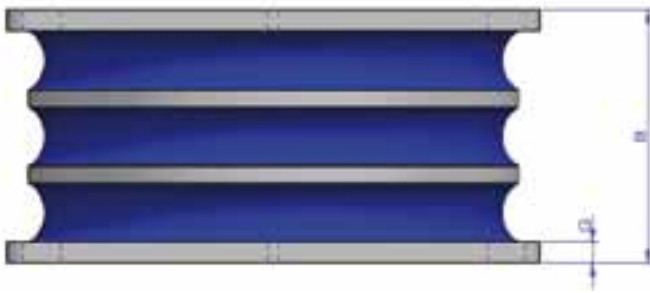

TYPE	B	D	E	F	G	AMC		CODE		WEIGHT (Kg)
						45 Sh	60 Sh	70Sh		
SH 150	63	136	166	13,5	6	Ref	148201	148202		4,5
						Maxload(kg.)	3.750	7.500	*	
SH 200	82	184	220	17	8	Ref	148204	148205		9
						Max load (kg.)	6.000	12.000	*	
SH 300	120	270	310	22	10	Ref	148207	148208	148209	27
						Max load (kg.)	15.000	30.000	40.000	

DYNAMIC SH

AMC NATURAL FREQUENCIES
MECANOCAUCHO® SH TYPE

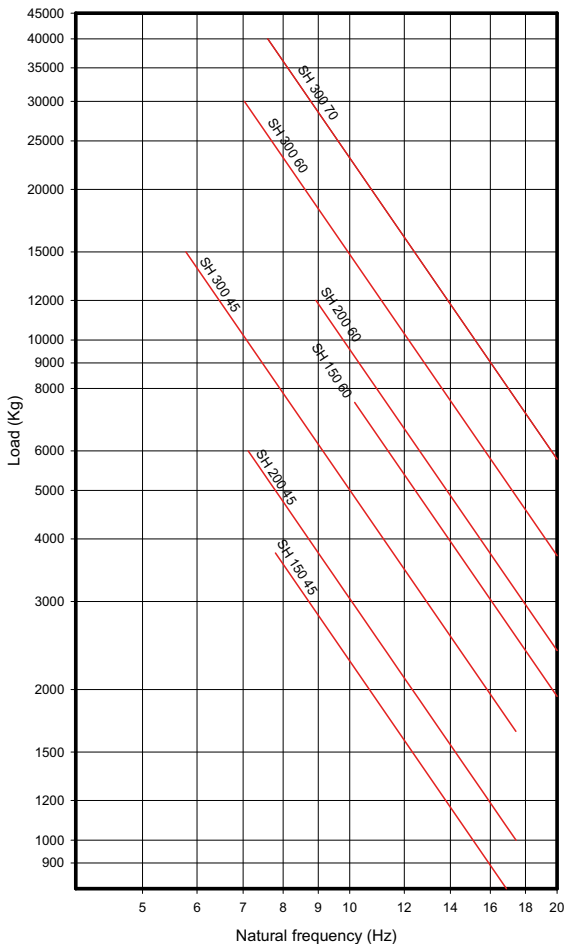

SH DEFLECTION

AMC LOAD DEFLECTION GRAPHS
MECANOCAUCHO® SH TYPE

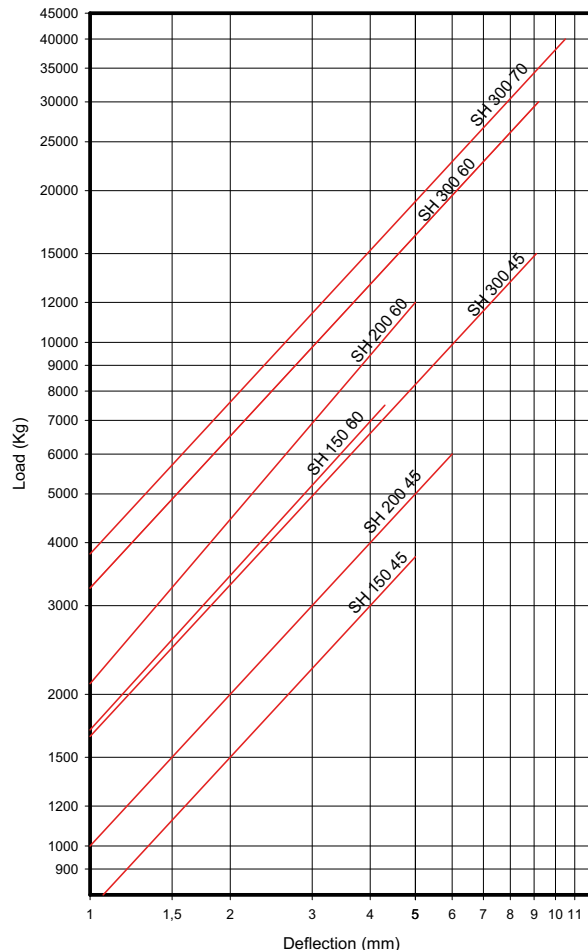

* In order to adapt its products to the state of the art, AMC .A. reserves the right to modify the conception and manufacture of the materials presented in this catalogue without prior notice