

# LEVELLING MACHINE MOUNTS



The N.F.-type AMC Mecnocaucho® mounts are used in cases where light or heavy machines should not be fixed to the floor or ground.

The height adjustment system can be used to adjust the machines to the required level, thus insulating from vibrations and reducing noise. The AMC-Mecnocaucho® type NF comes with a tilting system allowing optimum adaptation to all surfaces.

The elastomer used is a mixture of oil-resistant synthetic Nitrile Butadiene Rubber (NBR).

Height is adjusted by means of a screw, although this operation can even be performed once the machine has been assembled. The wide contact between the base of the machine guarantees good overall stability.

## INSTALLATION INSTRUCTIONS

Lift the machine and insert the mount under it.

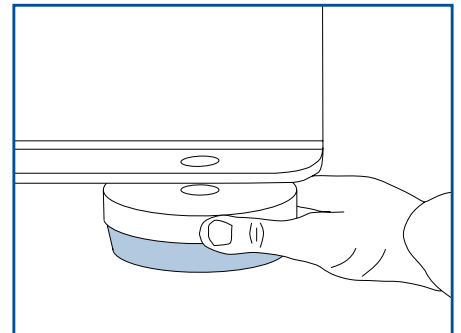

Insert and turn the screw manually until it slots into place.

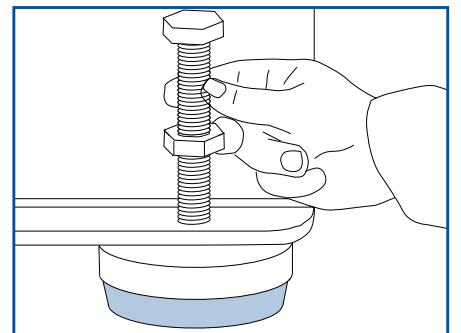

Adjust the height of the machine by turning the screw.

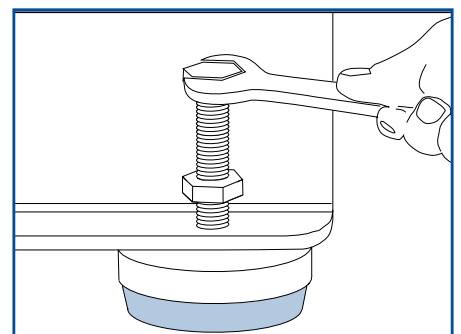

Block using the checknut.

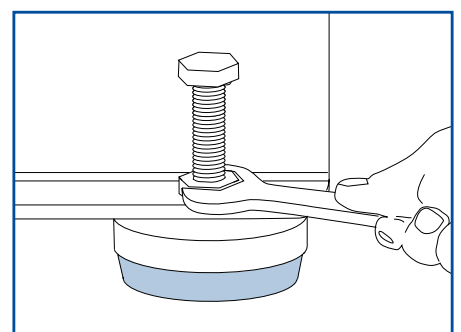

## MECANOCAUCHO® TYPE NF

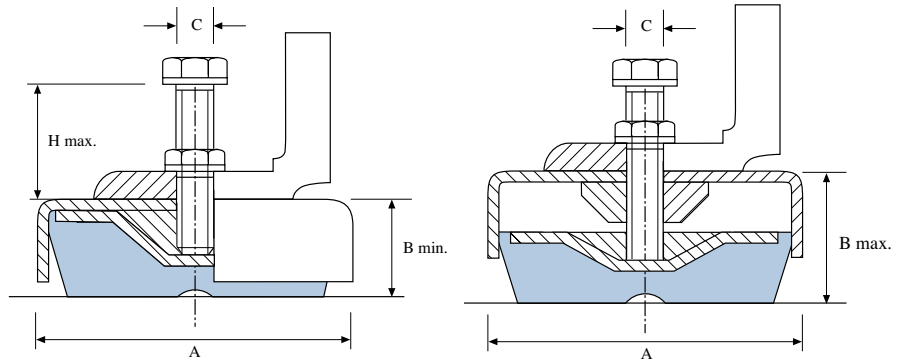
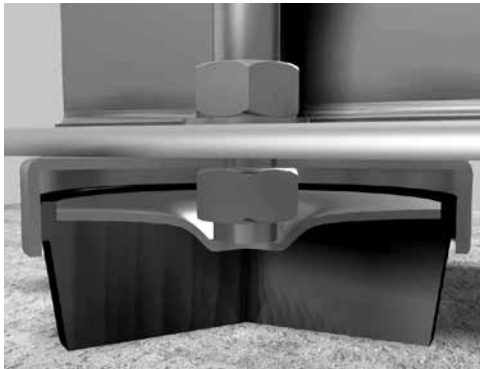

TYPE	A mm.	B mm.			H mm. Max	C	STATIC LOAD Nominal Kg.	DEFLECTION mm.	WEIGHT (g)	CODE
		Min	Max	Adjustm.						
NF-65	65	27	34	7	110	M-12	320	2	349	142001
NF-85	85	33	46	13	127	M-16	650	2	732	142002
NF-100	100	35	48	13	130	M-16	980	2	960	142003
NF-130	130	45	58	13	140	M-20	2.500	3	1.891	142004
NF-160	160	53	66	13	140	M-20	4.000	3	3.397	142005
NF-200	200	55	68	13	100	M-24	5.000	3	4.958	142006
NF-250	250	67	85	18	110	M-30	7.000	3	8.575	142007

## MECANOCAUCHO® NFR TYPE

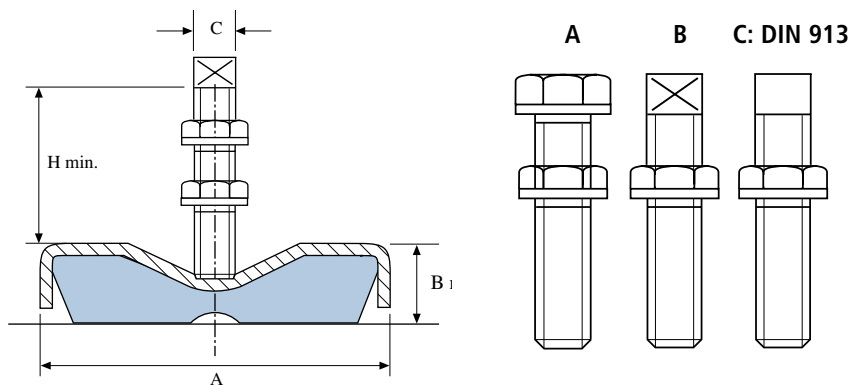

TYPE	A mm.	B mm.	H mm.	C	STATIC LOAD Nominal Kg.	DEFLECTION mm.	WEIGHT (g)	CODE
NFR-85	85	33	100	M-16	650	2	713	142009
NFR-100	100	35	100	M-16	980	2	929	142010
NFR-130	130	45	130	M-20	2.500	3	1.832	142011
NFR-160	160	53	130	M-20	4.000	3	3.330	142012
NFR-200	200	55	140	M-24	5.000	3	4.924	142013