

# INSTALLATION PRINCIPLES

## RECOMMENDATIONS FOR HOOD MOUNTS

The hood mounts should be installed between two parallel and perfectly flat surfaces. Mounts operating tilted or twisted do not work properly. This may be due to incorrect alignment, tolerances in the building of the chassis or over-tightened torque during the installation of the Antivibration mounts.

This applies to our marine-type, BSB, BRB or Mecanodamp mounts.

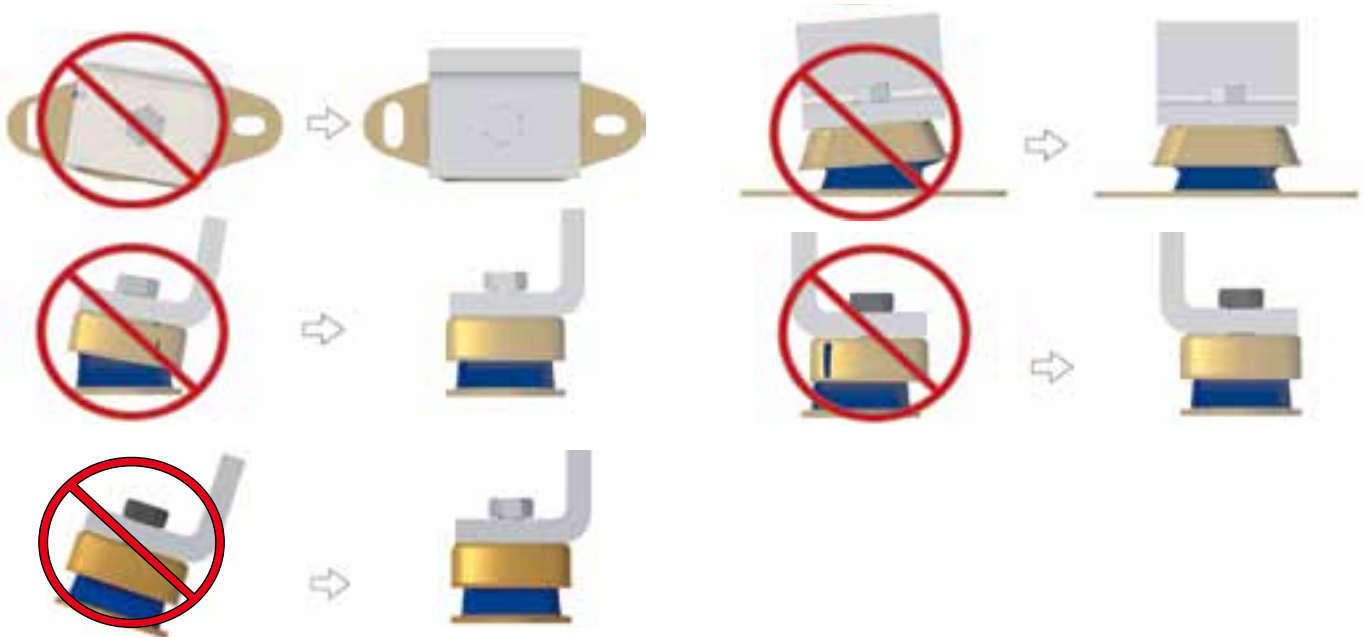

## RECOMMENDATIONS FOR THE CONICAL MOUNTS

The conical mounts should always use the washers indicated for each model.

Similarly, we recommend the use of lateral limiters for cases with high loads or radial impact.

This applies to our AT, SCB, SCH or Mecanocaucho® mounts.



Anti-rebound washers



Radial load limiters

## RECOMMENDATIONS FOR THE DSD AND DRD MOUNTS

Although it is not absolutely necessary, the AMC Mecanocaucho® hoods should be used in the DSD and DRD hoods. This hood distributes the load evenly in the event of overloads, and also provides protection from possible oil splashes.

Care should be taken to make sure that the protective hood has the same or a greater diameter than that of the diameter of the rubber element.

We have a standard range of Mecanocaucho® protection hoods. Check them out.

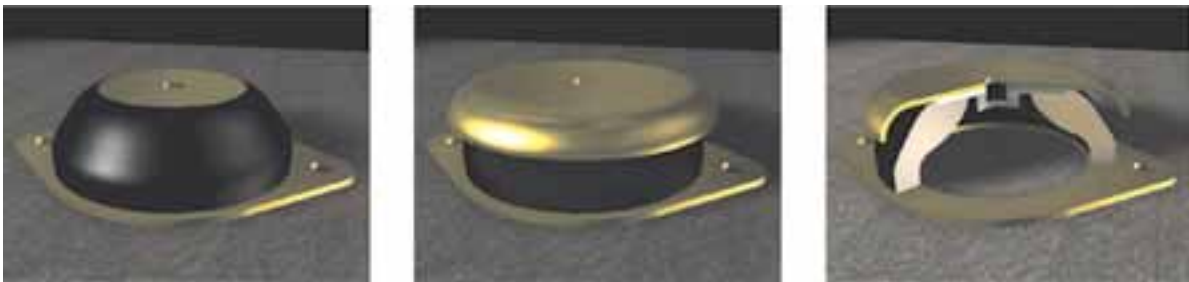

## RECOMMENDATIONS FOR THE CYLINDRICAL MOUNTS

The cylindrical mounts should never work at traction. They should be used on a compression basis. To obtain greater deflection, use them at shear or shear /compression, although the maximum loads indicated in our catalogue for shear use should never be exceeded.

This applies to our bobbins, diablo, trapezoidal or annular mounts.

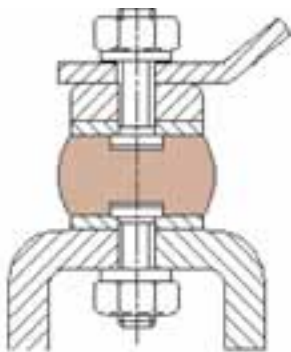
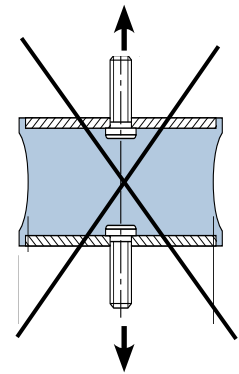

**Compression**

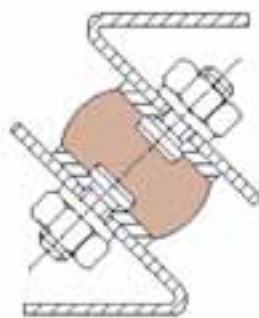

**Compression-shear**

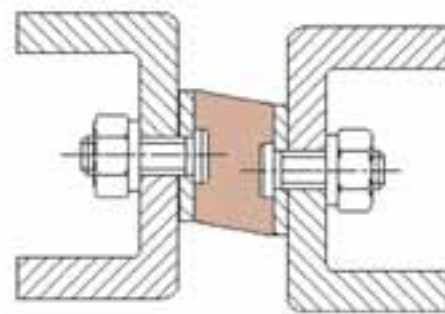

**Shear**

## RECOMMENDATIONS FOR MACHINES THAT REQUIRE ALIGNMENT

When an alignment is required between different mechanical elements of the machine, the creeping effect should be taken into account. The increased deformation produced by the creep of the elastomer leads to a "misalignment" between suspended and rigid elements, particularly during the first 48 hours of static load in the antivibration mounts.

Alignment should therefore be checked 48 hours after the installation of the machine.

If this is not possible contact AMC's technical department and they will help you to ascertain the optimal alignment of your machine.

## RECOMMENDATIONS FOR AMC MECANOCAUCHO® MACHINE MOUNTS WITHOUT ADJUSTABLE HOOD

On installing one of our AMC Mecnocaucho® machine mounts without adjustable hood, great care should be taken to ensure that the load of the machine does not rest on the screw, but on the hood.

This applies to our AMC Mecnocaucho® SV, SM and low SV series mounts.

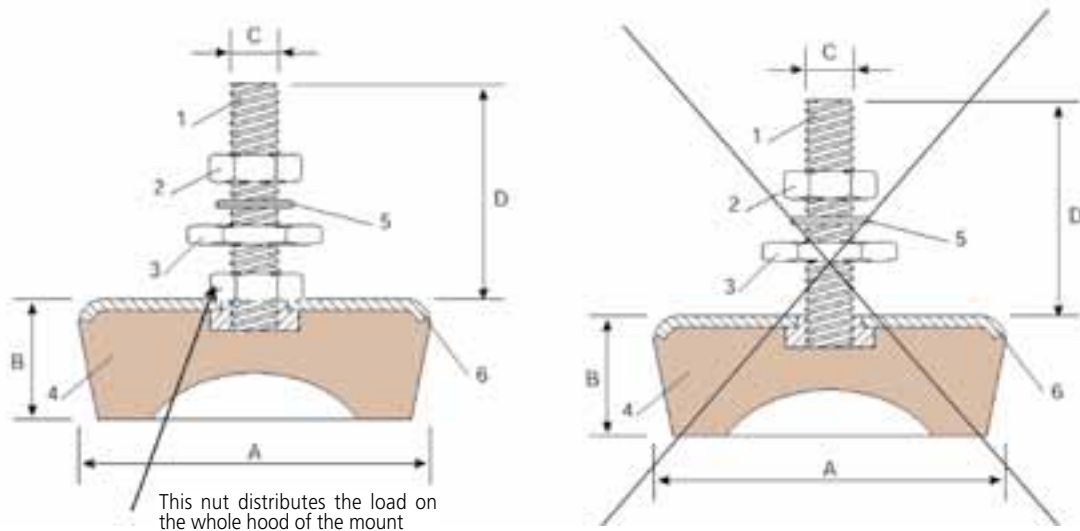

## RECOMMENDATIONS FOR TORQUE TIGHTENING FOR THE BRB, BSB, MD AND MARINE MOUNTS

Before installing, make sure that the support surfaces are sufficiently rigid

Flat and totally parallel. The main fixing screw should be tightened according to the torques recommended in the following chart:

	M8	M10	M12	M16	M20	M24
Tightening torque in Nm	16	32	55	125	190	285

## RECOMMENDATIONS FOR THE INSTALLATION OF ANTIVIBRATION MOUNTS

The position of the antivibration mounts determines the vibration modes of the suspended ensemble. An even load distribution over all the mounts is advisable. One easy way of obtaining this is by installing the antivibration mounts equidistant from the CDG of the ensemble.

Mounts installed at the height of the crankshaft provide more stable suspensions and avoid over-movement of the suspended ensemble, particularly in mobile or moving applications.

The external connections to the suspended ensemble, such as cables, exhaust, hydraulic pipes, etc., must be elastic enough to prevent vibrations from being transmitted to the chassis through them.

